

1	2	3	4
---	---	---	---

Rev	ECN NO:	DESCRIPTION	APPD

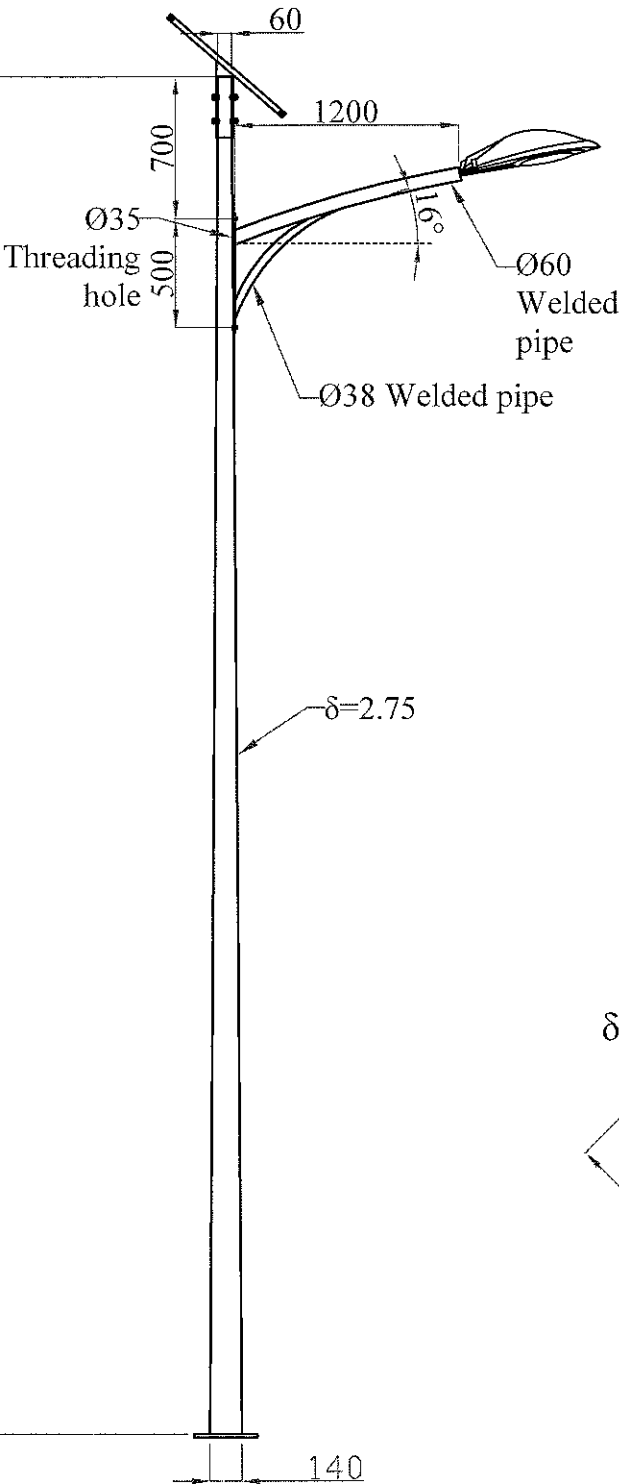

Technical requirements

- 1, Made of high quality Q235 steel
- 2, hot galvanized, 610g up / per square meter , surface spray treatment.
- 3, The flange is welded on all sides, The weld is smooth and the strength is up to standard
- 4, All to be involved in the threading of the hole, not marked size, aperture 30-35mm
- 5, Made in strict accordance with the size of the drawings
- 6, Unit:mm

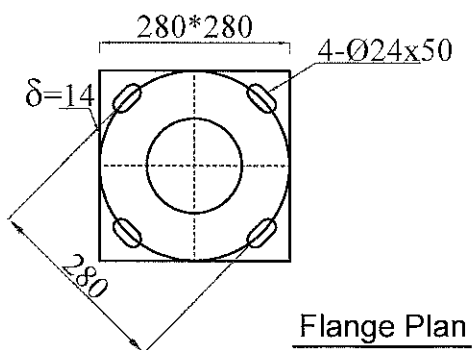

A
B
C
D
E